

Professional One-Day Training Course in BIM: A Practice Overview of Multi-Applicability in Construction

Alcnia Zita Sampaio* , Augusto M. Gomes 

Department of Civil Engineering, University of Lisbon, Lisbon, Portugal

Email: *zita.sampaio@tecnico.ulisboa.pt, augusto.gomes@tecnico.ulisboa.pt

How to cite this paper: Sampaio, A.Z. and Gomes, A.M. (2022) Professional One-Day Training Course in BIM: A Practice Overview of Multi-Applicability in Construction. *Journal of Software Engineering and Applications*, 15, 131-149.

<https://doi.org/10.4236/jsea.2022.155007>

Received: March 23, 2022

Accepted: May 27, 2022

Published: May 30, 2022

Copyright © 2022 by author(s) and Scientific Research Publishing Inc.

This work is licensed under the Creative Commons Attribution International License (CC BY 4.0).

<http://creativecommons.org/licenses/by/4.0/>



Open Access

Abstract

The implementation of Building Information modelling (BIM) methodology in the construction industry has been covering wide applicability with recognized benefits in designing, constructing and operating buildings. A recent short course organized in the University of Lisbon, actualized with the most relevant achievement based in master research, was offered to professionals of the industry, namely, architects and civil engineers coming from diverse engineering areas, environment, construction, maintenance, consult and patrimonial enterprises and also from public organizations like city councils. The proposed action covers the areas of construction (conflict analysis, planning and materials take-off), structures (interoperability, analyses and transfer of information between software) and the most recent Heritage Building Information Modelling (HBIM) topic. The course aims to contribute to the dissemination of the potential of BIM in the areas of designing, construction and refurbishing of historical buildings. The participants followed the course with great interest and satisfaction, formulating several questions directed to the particular activity of each of the attendees.

Keywords

BIM, Training Course, Up-to-Date Information, Improve Professional Skills

1. Introduction

The Building Information Modelling (BIM) methodology is currently the main digital support to the elaboration of diverse construction activities. A BIM project is developed over a technological platform, in which all experts create, manipulate and add the information that is required and generated in the context of the work of each professional involved [1]. In this process, the methodology

supports the development of different components of the project, allows adequate interoperability between specific systems related to various types of analysis or simulation, facilitates the tasks of budgeting, construction, maintenance and management, and controls the procedure for a possible demolition [2].

The BIM concept began to be implemented in the construction industry at the present century as an immersive innovation in the sector supported in advanced technology. Its benefits were quickly recognised, reflected in the quality of the projects developed, based on effective process integration and clear collaboration between partners related to the different specialties intrinsic to construction [3]. BIM computational tools are a strong support for the improvement of the different disciplines of the project, enabling their parametric modelling and easy access to all the information concentrated in the BIM model, created along the elaboration of a project.

In all areas of the construction activity, the construction owner, designers, builders and managers, has verified the benefits of adopting BIM methodology. This fact has led to its growing acceptance, at a global level and in an exponential way, leading government entities to establish rules of action and mandatory implementation dates in public construction [4]. In addition, the school has the mission, essential in society, to train future engineers with the fundamental teachings related to different issues in the field of construction, and should also be focused on the technological innovations that can be applied in the sector. Naturally, construction-related companies follow this perspective, encouraging professionals to seek training actions that can add to professionals the BIM knowledge required in a globalized industrial world, increasingly competitive.

A short course, presented in March of 2022, include the methodological concepts and a wide range of the applicability in all sectors inherent to the development of projects using BIM platforms. The text includes the contents of the course and its main objectives. The organizational structure of the course introduces the underlying fundamentals of the methodology, such as parametric modelling and interoperability, and presents the scope of the applicability of BIM. The most recent research achievement in BIM applications were resumed and presented to the professional course participants.

2. BIM Education

Currently, the attention of Civil Engineering education is oriented to BIM, and it is up to the school, as the main trainer of the future engineer, to introduce this theme, as a concept that should be transmitted, contributing to support all new subjects, included in the curriculum, on a BIM-based digital support. The requirement of BIM skills in the sector has imposed an educational maturity of alert in relation to the need in society, which has led to a progressive adaptation of the curricula taught [5]. The most recent demonstration of the benefit inherent to the use of the BIM methodology, has been registered in the various sectors, motivating designers and managers to acquire knowledge related to the

concept and scope of its applicability. Professionals from all sectors are interested in knowing the BIM concept and the scope of its applicability and technical schools organise BIM training activities to help to add knowledge and competitiveness to industry professionals.

The school have been contributing positively to the updating of knowledge of professionals in the sector, through the organization of BIM training courses, in accordance with the interest and expectation expressed by the offices and public entities. Industry and the school are partners in finding the best strategy for establishing effective ways of teaching useful to the community. In Europe, BIM training has been essentially introduced into postgraduate studies as curricular modules, disciplines or specialization courses. In reference universities, in Spain, Switzerland, Portugal and Italy, the curricular research points to a relatively rapid assimilation in engineering training:

1) The *Escuela Técnica Superior de Ingenieros de Caminos, Canales y Puertos* of the Polytechnic University of Madrid offers two curricular actions [6]: a discipline of specialization, within the framework of the Master's degree in construction and management of facilities, with the aim of training professionals in the application of the BIM methodology, covering the entire life cycle of a building (project, execution and operation of the building), and the use of software required in modelling and information management; an advanced discipline of BIM methodology, in the master course of project management, with a more specific and detailed programmatic content (concept and applicability, BIM model management, collision detection, collaborative workflow, conservation and exploitation of infrastructures);

2) At the *École Polytechnique Fédérale de Lausanne*, the study plan identifies the introduction of BIM at master's level through a discipline of fundamentals and application of BIM, covering the teaching of concepts (interoperability, IFC standard and LOD levels), the generation of parametric models and conflict detection analyses, the transfer of information between systems, the estimation of costs and construction monitoring;

3) At the *Instituto Superior Técnico* of the University of Lisbon, at the level of the 1st cycle of teaching, the curriculum of the discipline of Technical Design includes an introduction to BIM, where the procedure on parametric modelling is transmitted, using BIM-based tools;

4) The curriculum, of the *Collegio di Ingegneria Civile*, at Polytechnic University of Turin, offers in the 2nd cycle of education, a master's course in BIM applied to infrastructure, which includes aspects related to modelling and computer content, interoperability and formats, collision detection, structural dimensioning and real case analysis (bridges, tunnels, stations, schools and hospitals).

In addition, the construction industry has demanded from schools an offer aimed at the specificity of the profession, focusing on different perspectives. Engineers and architects recognize that in a globalized world, in the pursuit of their

activity, the use of BIM platforms, leads to the achievement of better products and the establishment of more competitive projects. The constant demonstration of the benefit inherent to the use of the BIM methodology, which has been registered in the various sectors, motivates designers and managers to acquire knowledge related to the concept and scope of its applicability. Professionals from all sectors are interested in knowing the BIM concept and the scope of its applicability and technical schools organise BIM training activities to help to add knowledge and competitiveness to industry professionals.

BIM is one of the most advanced methodology applied in architecture and civil engineering in recent years, therefore it becomes important to promote its integration into university education. The pedagogic aspects must be also considered when establishing new teaching strategies [7].

Following this, several modules, workshops and short courses have been offered to the professionals: a three-day workshop course, Virtual Project training, is offered to professionals working at small and medium enterprises or large contractors with the objective to experience BIM in a real-life collaborative environment [8]; a BIM course, structured as a lecture-lab sessions combination, was implemented in the University of Texas at San Antonio, in USA, where the students are asked to complete individual projects and present them in different formats, allowing to provide a sample structure to deliver BIM content [9]; some difficulty of introduction BIM concept and tools management is also reported, as the students presents different technological abilities and skills [10]; the course BIM Implementation Training Course, a 1-day live online training action, make BIM understood concerning the strategic and technical processes required to apply BIM on all levels, allowing to increment the knowledge and skills of the professionals [11]; in the Architectural Technology and Construction academy, in Barcelona, provides students to acquire the BIM skills related to construction, maintenance, rehabilitation, deconstruction and urbanization [12]; the graduate degree program in Architecture, in Italy, offers students adequate knowledge of architectural and construction history and innovative representation forms by using techniques and BIM-based tools [13]; Taylor *et al.* [14] defends the perspective that students must work on a project of challenging scope and complexity in order to more fully understand the extent of developing a BIM model; Huang [15] introduce a modular BIM action in construction education, focused in a speedy adoption of BIM in the architecture, engineering and construction management programs in the USA technical academies.

3. Professional Course

The professional course, *BIM methodology: construction, structures and HBIM*, presented on March 2022, included within the activities of the Department of the Civil Engineering, of the University of Lisbon, was the most recent event offered to professionals of the construction industry. The range of professionals, that attended the course, in number of 15, englobes architects and civil engineers coming from consult enterprises and public organizations. The objective in at-

tending the course was to improve their skills in order to increase individual competences in each particular domain of activity in construction. The program is presented in **Table 1**.

3.1. Introduction to BIM

The introduction of the main fundamentals of BIM concerns the concept, the range of applicability in a global perspective and the state-of-the-art of its implementation (**Figure 1**). The central BIM notion is the generation of a centralized digital model formed with all construction-related information. The BIM model is frequently defined as a digital representation of the building or infrastructure, strongly supported by parametric modelling and standard format of data. The model assist the elaboration of collaborative projects that can be performed over the model, requiring the use of advanced technologies and a high level of interoperability.

Table 1. Professional course *BIM methodology: construction, structures and HBIM*.

Topic	Contents
Building Information Modelling (BIM)	Concept, applicability and implementation; Parametric modelling, interoperability, and centralization; BIM tool practice in generating model structures.
BIM in the construction	Conflict analysis; Adding parameters to objects; Construction planning; Quantification of materials.
BIM in structural design	Interoperability; Transfer and consistency check; Graphic documentation and information centralization.
Heritage Building Information Modelling (HBIM)	Concept and collection of information; Digital capture of images (photogrammetry, scanner and drones); Generation of specific families of parametric objects; Documentation file (as-built); Practical case: reconversion of a heritage building.



Figure 1. Slides of the professional course.

A practical lesson concerning the use of BIM-based tool, introduces the concept of parametric modelling, essential, to the understanding of the development of multitasking. In the modelling process, the first step is to define the base settings (work units, elevation levels, and alignments), followed by the selection and adaptation of parametric objects, associated to physical properties [16]. As an example of how to handling with a BIM-based tools, a structural BIM model was created (Figure 2). After, there were obtained several tables of take-off of materials and elements from the generated BIM model [17] (Figure 3).

3.2. BIM in Construction

An analysis of conflicts detection between distinct projects was also exposed to the audience. The BIM modelling tools allow the overlap of three disciplines (architecture, structures and mechanic) and support the definition of each component by direct analysis of conflicts, identified by the system with the

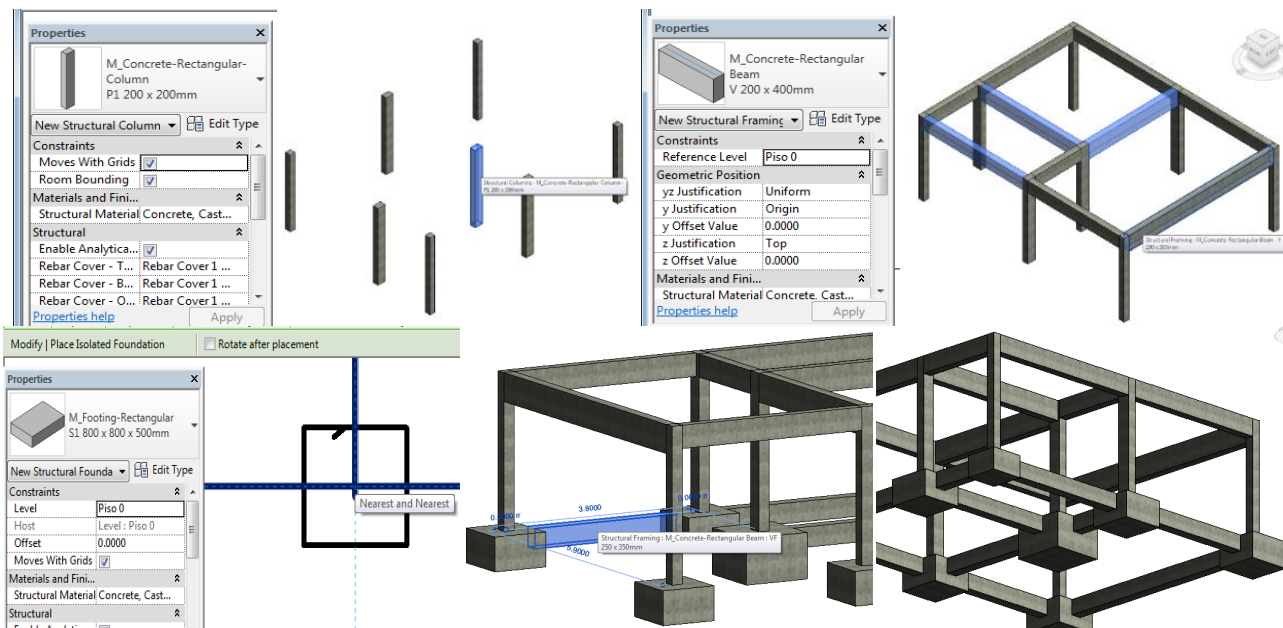

Figure 2. Modelling columns, beams and foundations.

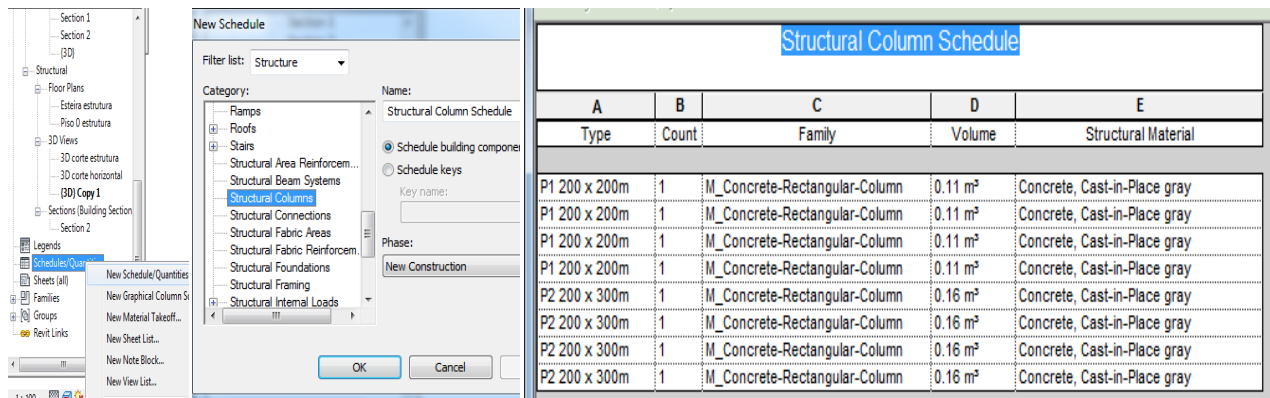

Figure 3. Interface with selection of a new schedule and table of columns extracted from the model.

presentation of inconsistency messages. There are several software with conflict analysis-oriented capability, namely, Tekla BIMsight, Navisworks, and Solibri Model Checker tools. After running any of these systems, the modeller adjusts each conflict situation over the BIM model. In the study case shown in the course, the models of water system and structures were overlapped and an analysis of inconsistency was applied. Using Navisworks and Tekla BIMsight a set of conflicts were listed and visualized (Figure 4). The conflicts detected were after adjusted accordingly in order to obtain correct situations (Figure 5).

The course also illustrates how to generate a 4D BIM model, relating to the construction process of a buildings [18]. First, the complete 3D BIM model of the structural project must be defined and after the constructive sequence planning (phases and periods of implementation or placement) and allocated human resources must be established in the form of a Gantt map (Figure 6).

The 4D model is then created in the Navisworks software, a BIM viewer. The BIM model, representing the structural project, is exported from the modelling system to the BIM viewer, performed in the native format of data, allowing a height level of interoperability. In addition, the construction-planning file (Gantt map) is transferred from the Ms Project system to the Navisworks. Next, it is necessary to associate the elements of the imported model, forming groups (sets), according to the activities of the schedule (Figure 7).

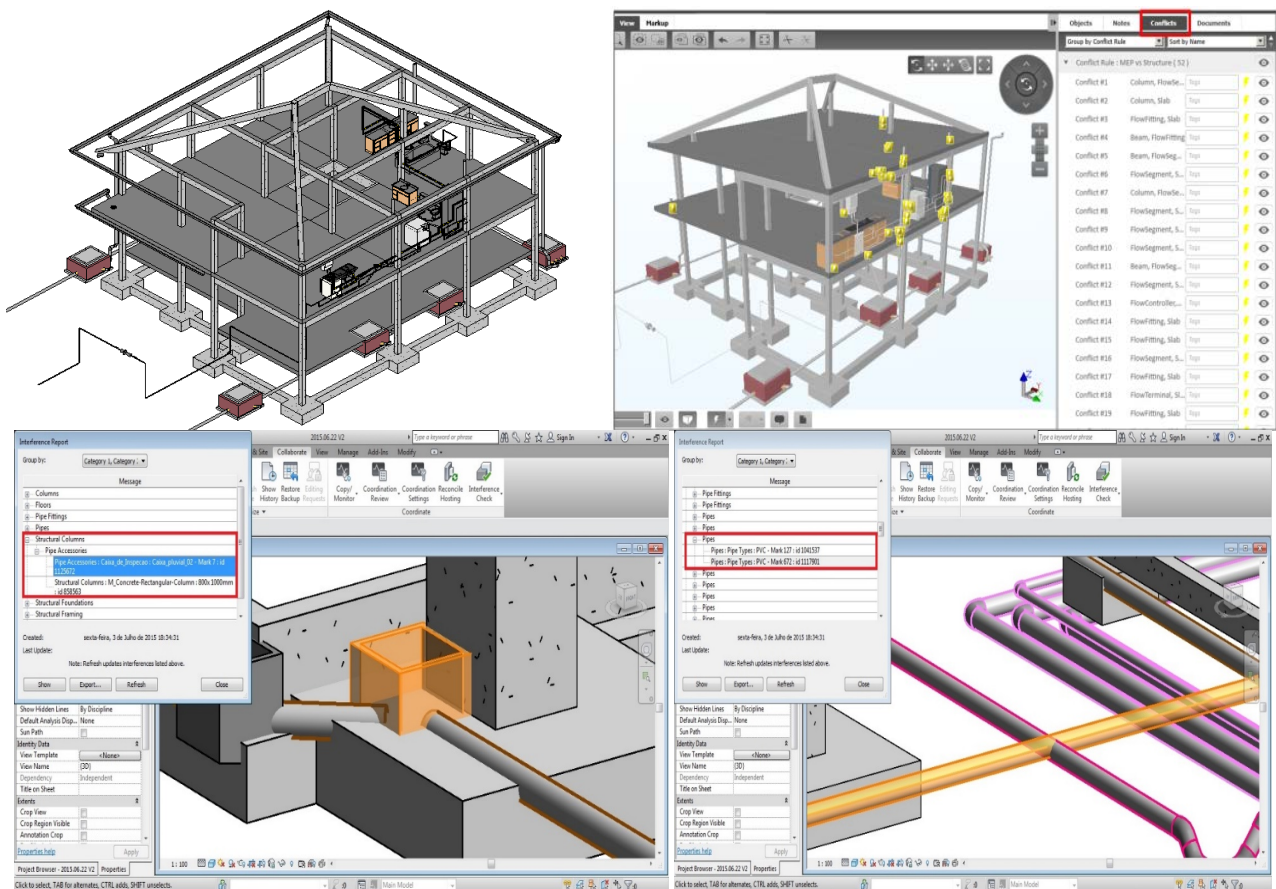

Figure 4. Analyses of conflicts between models.

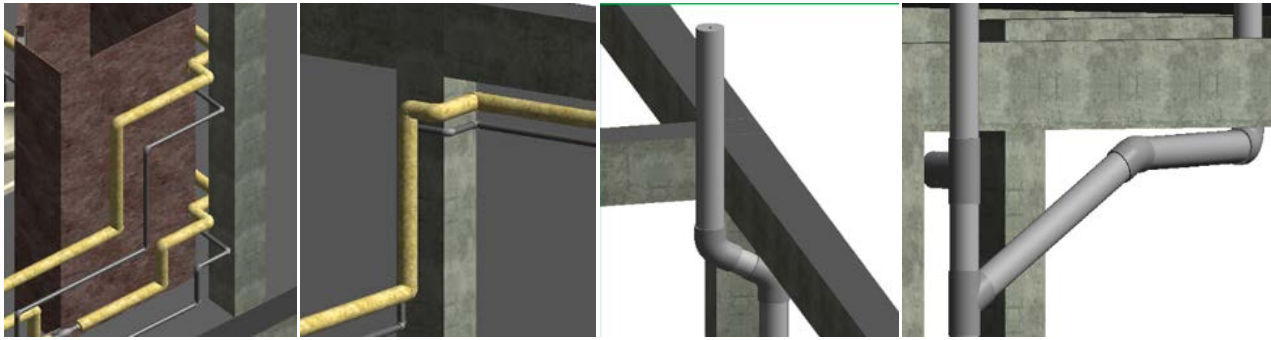

Figure 5. Changes were performed in a BIM modeler software.

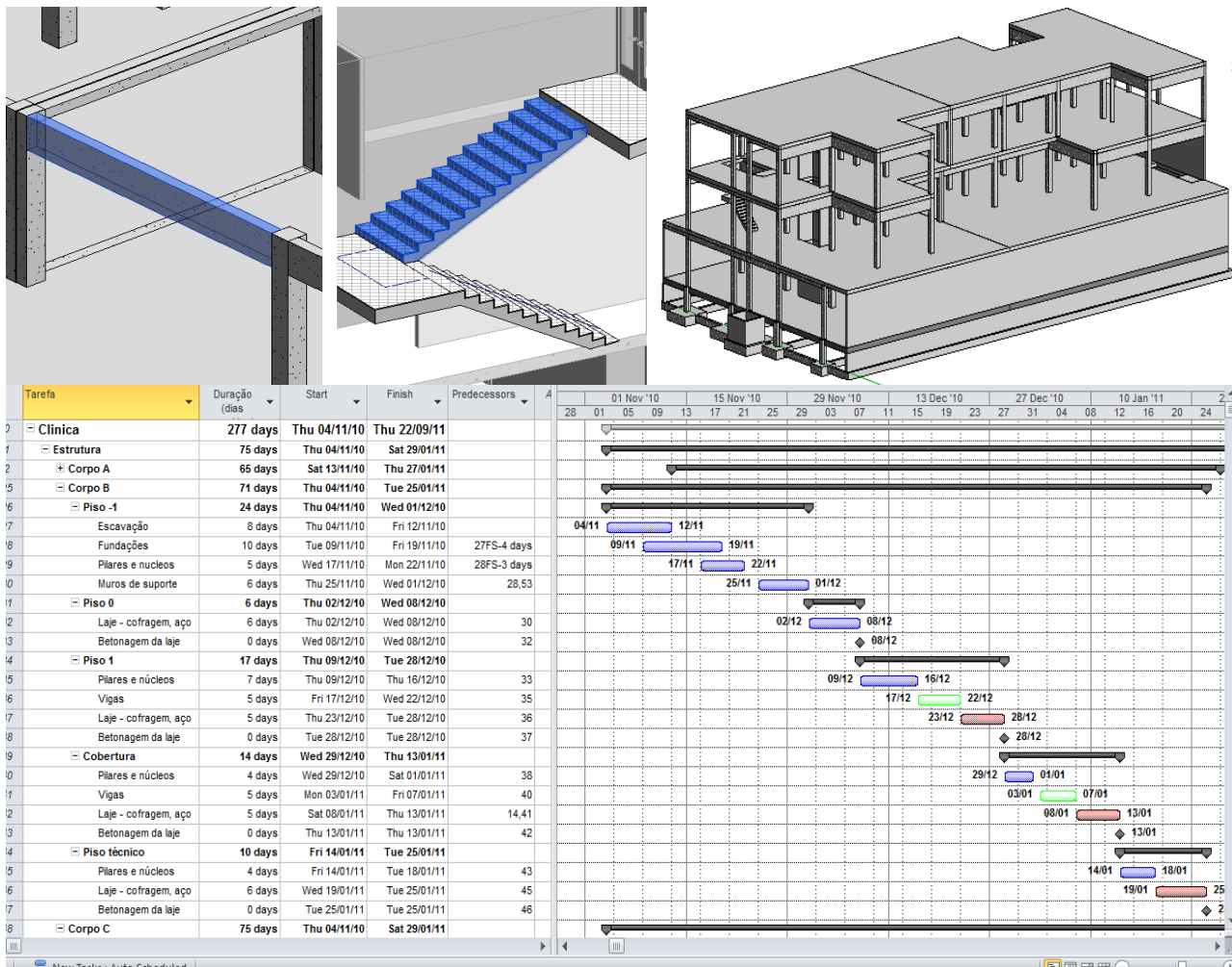

Figure 6. 3D BIM model of a structural project and the respective Gantt map.

Obtaining the correct and detailed 4D model, the simulation of the construction can be visualize (Figure 8):

- 1) Elements must be modeled by floors or zones that correspond to the actual construction process;
- 2) Consider the modeling of temporary elements to support the execution of the work (scaffolding, cranes, excavations and aid);

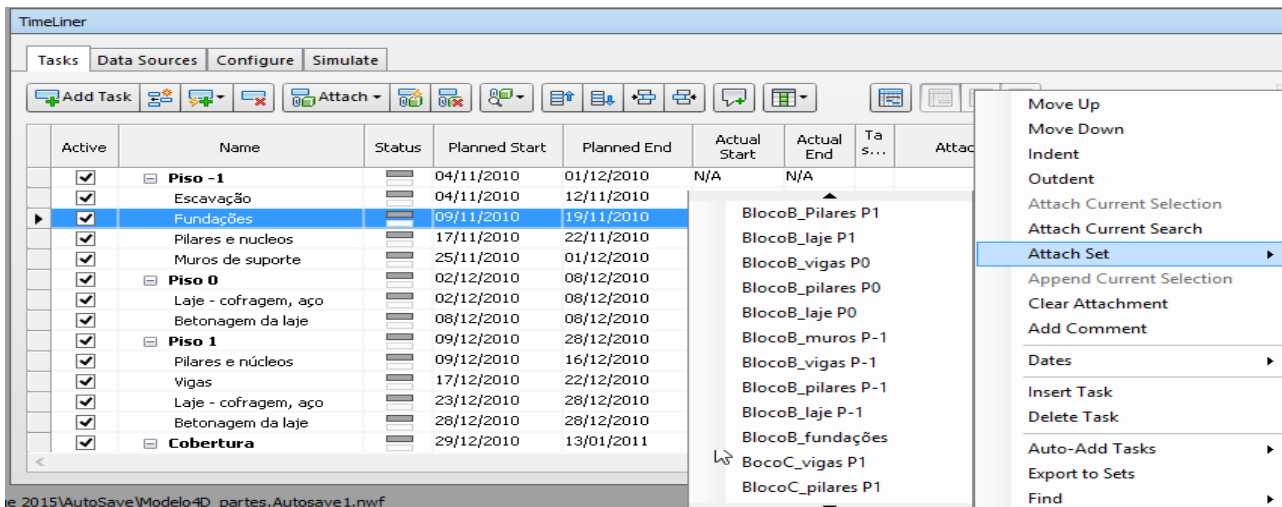

Figure 7. Association of sets to activities.

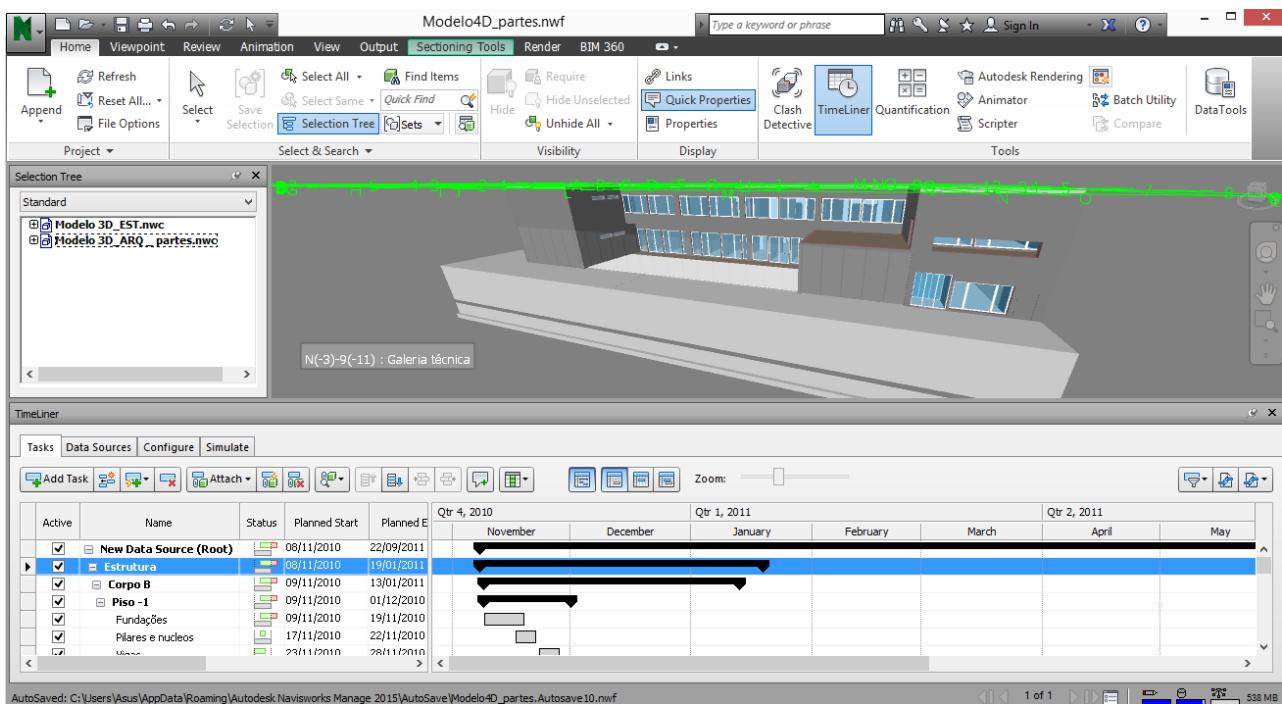

Figure 8. BIM 4D model generation and visual simulation.

3) The elements shall contain information, in their name or parameters, which facilitates their subsequent selection and association (blocks A or B and floor 0 or floor 1).

The 4D model allows to visually representation the planned construction process. The Simulate tab of the Time liner the Play option should be select in order to initialize the construction simulation animation (Figure 9).

The simulation can be exported through the *Animation* command on the *Output tab*, and allow to monetarize the real work in the site. Is also possibility to do a virtual navigation inside the model with the insertion of an avatar

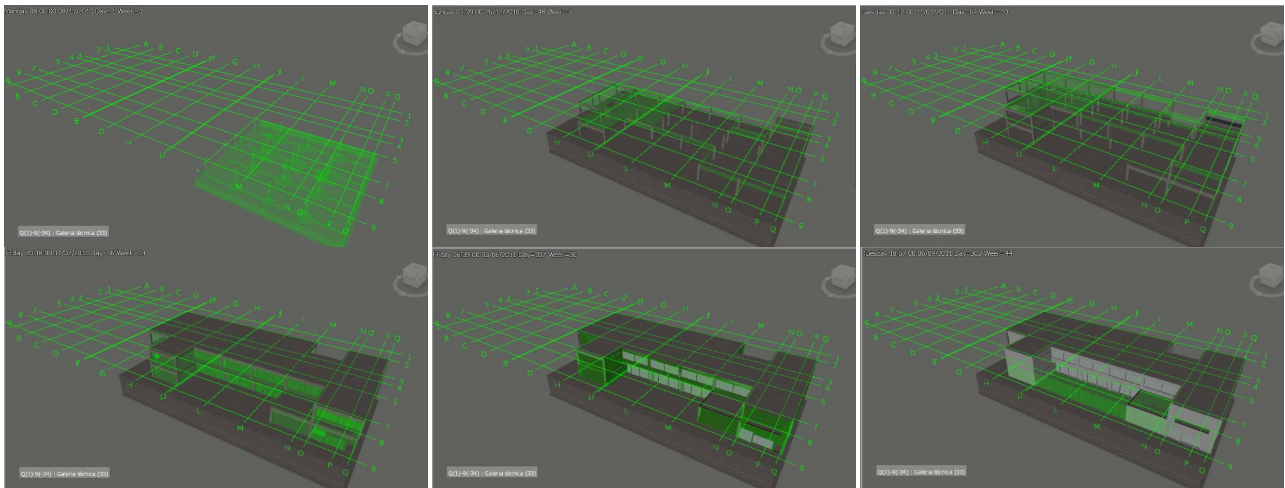

Figure 9. Simulation of the construction process performed within Navis work.

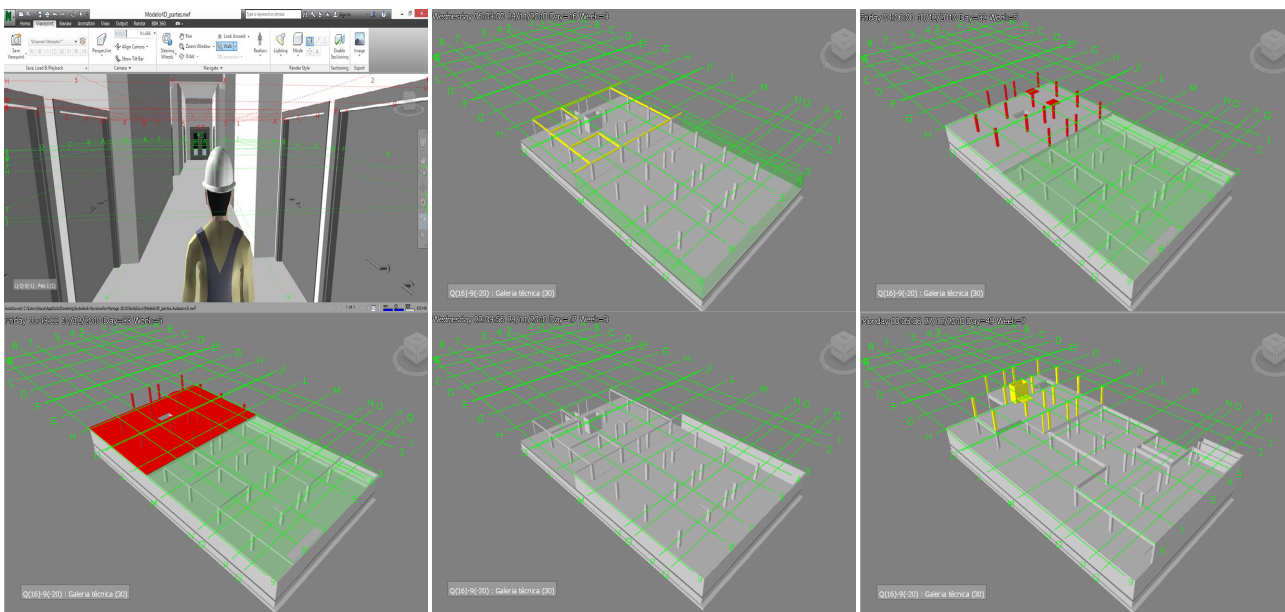

Figure 10. Virtual walking inside the construction site and comparison to the real progress.

(Figure 10). A comparison of the evolution of construction can be represented (Figure 10): executed (grey), progressing (green), early (yellow) and backward (red). The ability of the BIM 4D model to be transportable to the construction site supports the control of the real construction.

3.3. BIM in Structural Design

Along the development of a project and later construction and use, several processes demanding the transfer of data between software, are normally performed, and for that, a high level of interoperability is required. In a structural design, the transposition of models between BIM modelling and structural analysis tools is essential. Concerning the structural design, the interoperability capacity, the transfer and verification of consistencies and the centralization of information

and graphic documentation were presented in the training [19].

As referred, BIM methodology is based in two fundamental steps: parametric modelling process allowed by the modelling software available, being Revit the most used; interoperability capacity between software, when the transfer of models, created in ArchiCAD, Revit or AECOSim, take place to structural software like SAP, Robot and ETABS. In the course, the process of transposition of structural models between modelling and calculation systems (two-way flow) was analysed in several situations involving ArchiCAD, Revit and AECOSim modelling tools and SAP, Robot and ETABS structural dimensioning tools [20]. The transposition of models between systems is supported:

- in the native format, when the software belong to the same manufacturer;
- by recourse to the universal data transfer standard, the Industry Foundation Classes (IFC) format.

The interoperability capability analysis, verified in each model transposition process, is evaluated over several case studies of distinct volume and use. The architectural component was also modelled in order to illustrate the vantages of engineers and architects collaborate over a single and centralized model (Figure 11).

First, the BIM models were transferred from the modeler system to the analyses software and the geometric consistency was evaluated. Several inconsistencies were detected (Figures 12(a)-(c)): the stair elements were not recognized (remodeled as sloped slabs in the analyses system); the foundations were not transposed (considered as supports); the analytical axis of some linear finite elements and rigid connections required additional adjustments.

However, the structural elements (columns, beams and slabs) and the properties of the materials (concrete C30/37 and A500 NR SD steel) were correctly transposed (Figures 13(a)-(d)).

After the structural analyses was performed for each case:

- All loads and combinations were applied in each calculation system;
- The results are obtained in the form of diagrams and 3D models, deformations and efforts, as well as calculation notes;

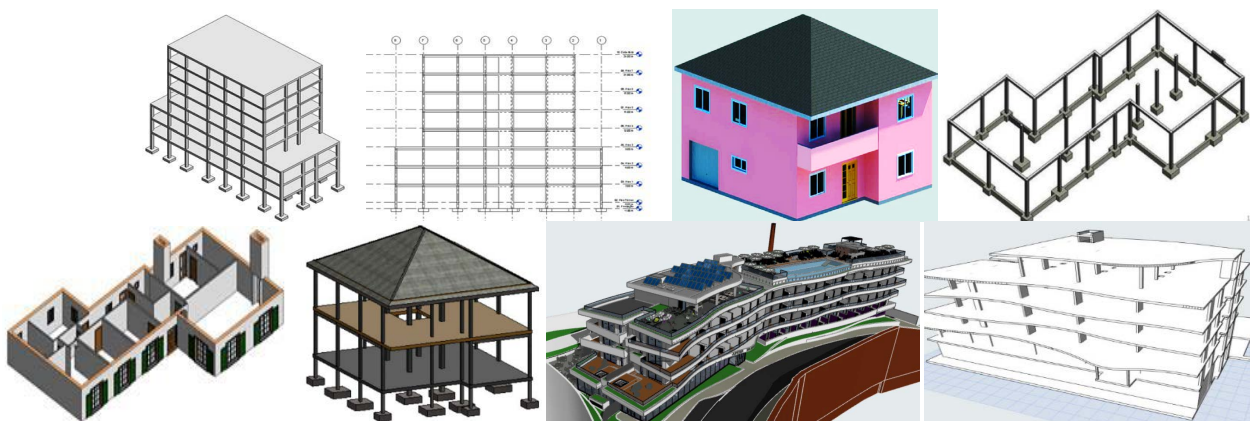

Figure 11. Architectural and structural BIM models of distinct buildings.

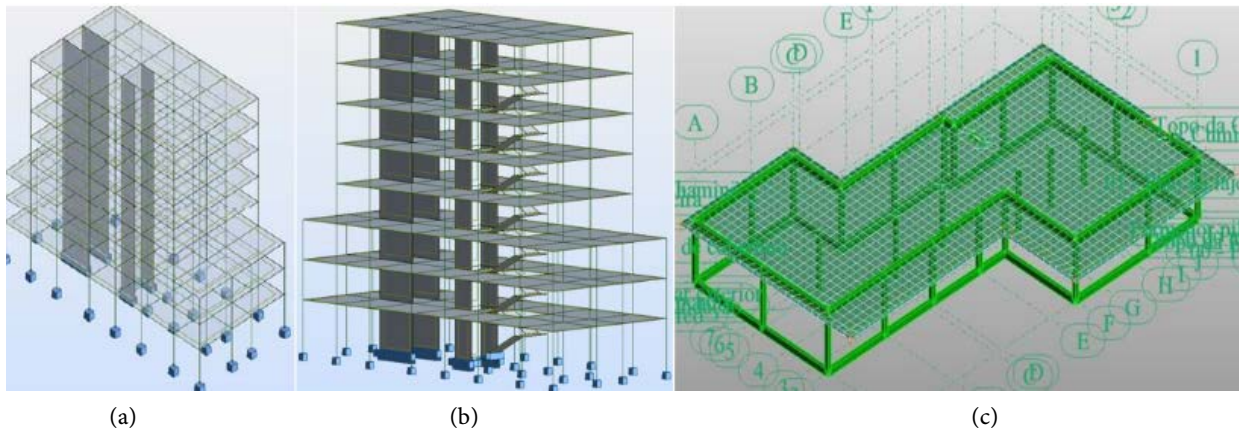

Figure 12. Structural BIM models transferred to the analyses software presenting inconsistencies (foundation’s (a), stairs (b) and axis of elements (c)).

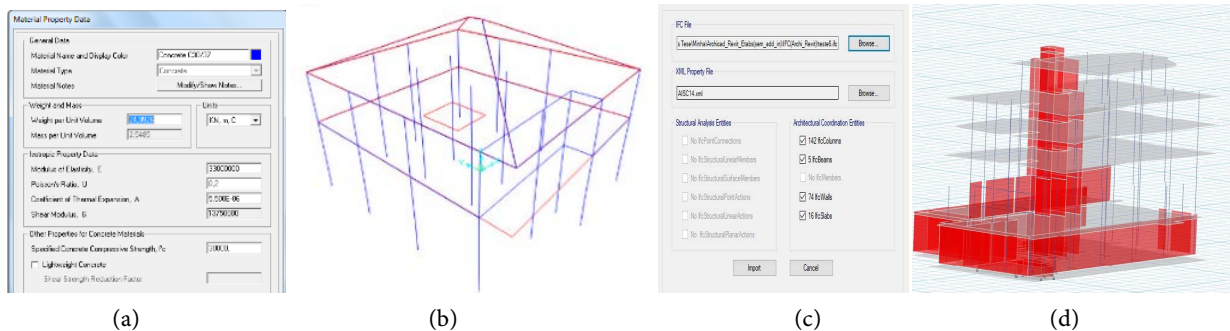

Figure 13. Structural BIM models transferred to the analyses software presenting correction of geometry of columns and beams (b) and slabs (d) and proprieties od materials (a) and (c).

- Calculation systems allow a high automation capacity of detail drawings, based on the reinforcement area of the given for each structural element.

Next, as required by the BIM centralization concept, the calculation result should be transferred to the initial BIM model. Also, the reinforcements were defined in the dimensioning software and after transferred to the initial structural model (Figure 14):

- The model database should be updated and should be accessible to the different technicians involved;
- The reverse transfer process, however, has a much higher volume of inaccuracies;
- Reason often pointed out to justify the resistance of the implementation of BIM in the design of structures.

The main remarks concerning the level of interoperability between BIM-based modelling and calculation systems was assessed. It was found that:

- There are advantages of using Revit/Robot integrated platforms; the data flow modelling/calculation can be done with confidence, while the reverse flow is inefficient;
- The advantages are essentially related to the easy initial modelling, with some ability to transfer information post-calculation;

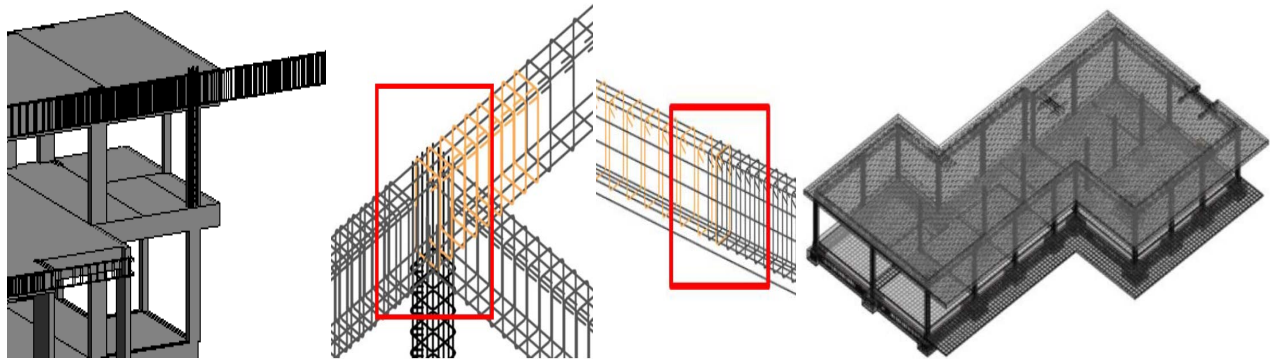

Figure 14. Inaccuracies detect with the reinforcements elements after transposition of models.

- It is appropriate to perform the detailing of reinforcements in the calculation system, as it allows a high capacity for the production of 3D designs and, subsequently, the inaccuracies are easily adjusted.

3.4. HBIM Concept

A recent implementation perspective the Historic or Heritage Building Information Modelling (HBIM) is directed towards properties of historical value or heritage relevance. Recent research related to HBIM addresses [21]:

- The standardization of architectural configurations and creation parametric objects representative of applicable and reusable forms in the old construction;
- The analysis of constructive techniques used in order to identify the materials used and the solutions applied;
- The archive of registration documents, studies carried out or previous interventions, and their availability for consultation by experts involved in the project.

It is required to understand geometric rules, in parametric terms, from the books of architectural patterns to the HBIM modelling process. Sets of specific parametric object must be generated to allow the generation of old buildings with accuracy (Figure 15).

The registered documentary information provides data concerning the characterization of the construction (historical epoch and traditional construction systems), the registration of refurbishing interventions and local inspection reports. In addition, the documentary collection, along with municipal archives, composed of drawings of plants, elevations and cut, referring to different dates and with yellows and reds, bring a complete description of the old building. The stratigraphic analysis covers the study of the constructive steps, which are represented through different colours, leading to a clear visual perception. In an HBIM process, it is also frequently necessary to establish a station of laser devices, properly positioned, so that, later, the points obtained can be unified, in a single cloud of space points (Figure 16).

A practical case of reversion of a building of heritage value was presented [22]. A proposal for the adaptation of an old building, located in Lisbon, requir-

ing the reorganization of internal compartmentalization, but preserving their architectural characteristics, illustrated an application of HBIM (Figure 17).

Although the BIM base tools, of current use, are more dedicated to the new construction, adapted to the geometry of the current architecture, the growing interest in the rehabilitation sector, has led to the incursion of the application of BIM in the support of the conservation of historic buildings. Old constructive solutions require adequacy libraries of parametric object, to enable the implementation of BIM, also in the recovery of heritage-value buildings.

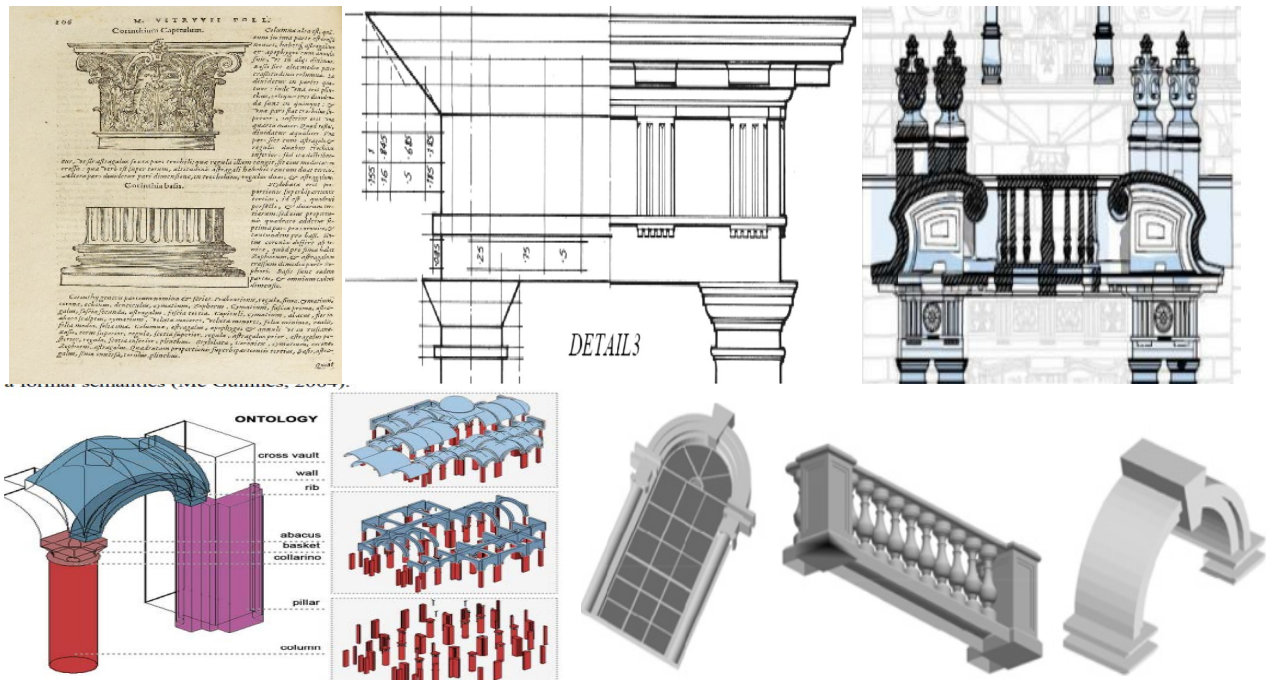

Figure 15. Architectural configurations and creation of parametric objects.



Figure 16. Current photograph report, stratigraphic representation and a drone.

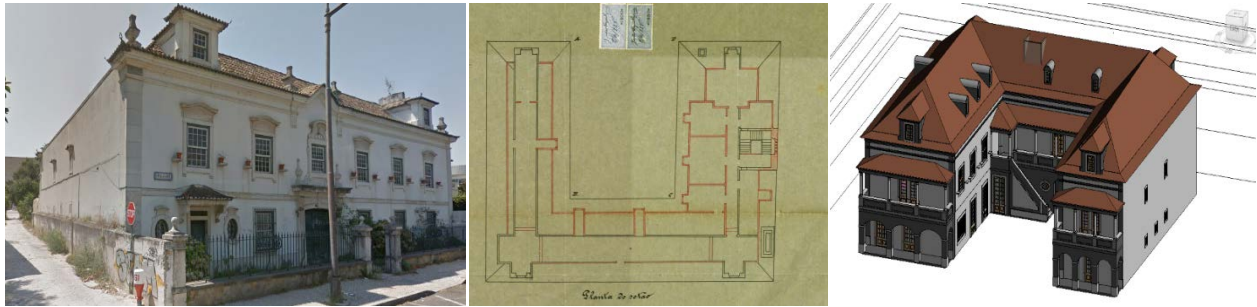

Figure 17. Building of heritage value, old drawing and BIM model of the proposal.

Within HBIM, the creation of families of specific parametric objects is normally required for the rigorous representation of buildings of patrimonial value. In the context of study case, as a basis for modelling, it was required to collect the existing documentation in the Municipal Archive of Lisbon, to obtain photographs from outside and inside of the building and the registration of detailed sketches. In addition, to allow a correct geometry represented in the form of parametric objects, it was necessary to add the material type and adjust the physical and mechanical properties, in order to respect the ancestral techniques of construction. The work contributes to empower the HBIM library of parametric objects of old building components. Namely, concerning a new library of windows (**Figure 18**) and doors (**Figure 19**).

3.5. Evaluation and Recommendations

The demonstration of the benefits inherent in the use of methodology for BIM in the construction industry, in the development of various activities based on the project, at a global level, motivates the great interest, which has recently verified by designers and managers to meet the BIM concept and the scope of its application. The course aim to contribute to the dissemination of the potential implementation of BIM methodology in sectors such as infrastructure, construction planning, conflict analysis, structural dimensioning or HBIM. The course was oriented to various levels and sectors of the construction industry.

Some comments and recommendation were also expressed. The comments of the participants to the course were oriented to a general and specific appreciation: The course exceeded expectations taking into account the time available, allowing an overview of BIM and its applicability; Important insertion of practical component in training, allowing participants to learn the fundamentals of BIM base tool use; The structural design was presented in all stages of modelling and data transfer processes, showing the limitations and the best strategy to elaborate this type of projects; The construction simulation capability was presented, showing the adequate way of creating construction planning and how to control the real work in the construction place.

Other topics were suggested that could be included in future BIM short courses: More practical component; BIM applied to underground works; Exploring BIM in management and coordination of projects; Training on other BIM-based soft-

ware; Generation and use of BIM 5D/6D/7D and 8D models.

It was found that in order to fulfill the industry requirements, the academia capacities should be oriented in that perspective, contributing to the society, as it is the most important role of a University. Schools should become leaders of the necessary partnerships with industry. To enhance better and fruitful contributions to the construction industry a collaborative approach between industry and academia should be instigate. The degree of satisfaction of the attendees is evaluated in **Table 2**.

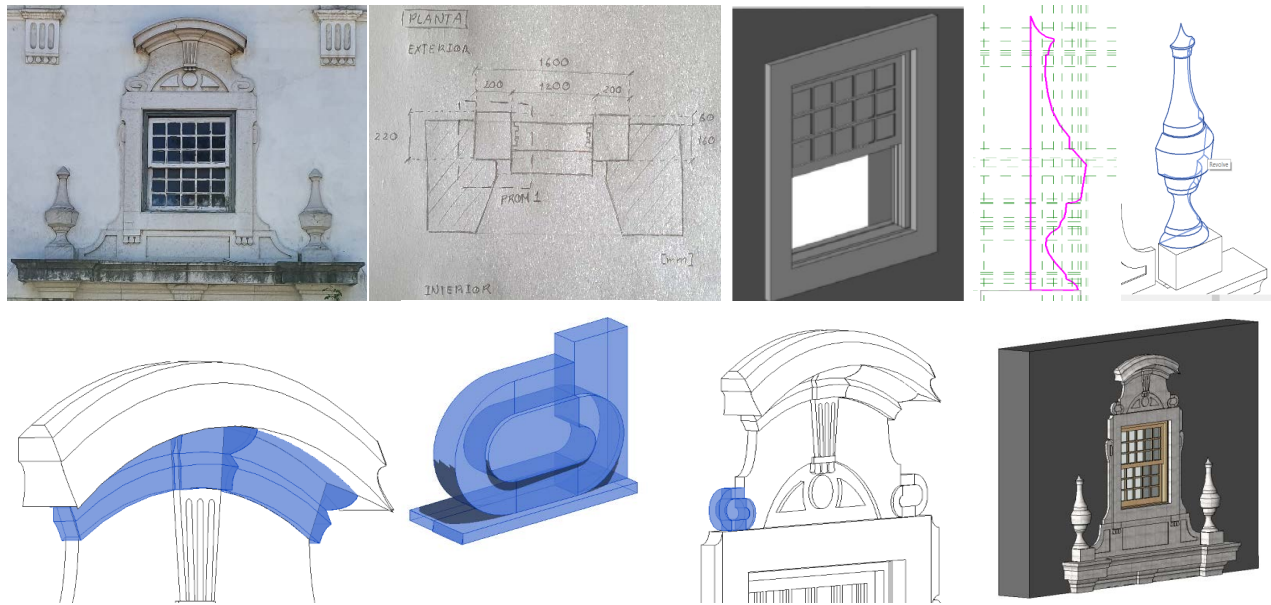

Figure 18. Image, sketch and sequence of the modeling process of a window.

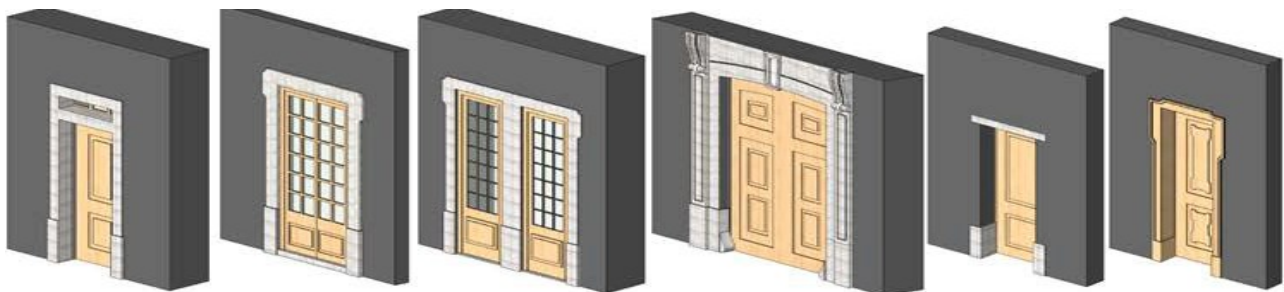
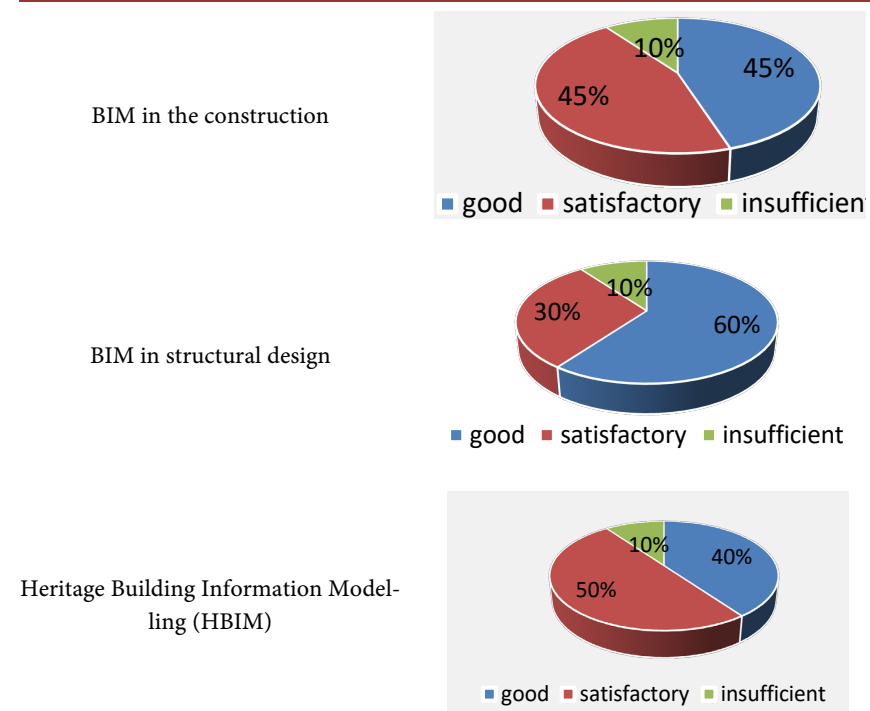

Figure 19. New parametric objects representing doors.

Table 2. Evaluation of the course *BIM methodology: construction, structures and HBIM*.



Continued



4. Conclusions

A one-day course, *BIM methodology: construction, structures and HBIM*, was offered, at the University of Lisbon, to professionals of the construction industry. The content of the training action was established in order to cover a wide range of the applicability of BIM in the sector, and with the most recent achievements. The participants demonstrated a global interest in all topics presented. The programmatic content of the BIM professional course was organized in order to attend the requests and interest of the construction industry.

The course was presented in a 1-day session. A practical component was included supporting an adequate base of understanding of the BIM multi-application, in order to meet the various interests of the participants. The participants were composed of professionals of different engineering sectors: civil, mechanical, electrical and informatics, as well as designers, architects and managers. The course initialized with an introduction to the innovative topic and covered a wide range of the applicability of BIM in the sector. Participants showed great interest in all the topics presented, often questioning the trainers, with a perspective of clarifying some doubts of their particular activity, depending if the background is construction, structures or heritage.

The main purpose of the course was to transmit the main concepts, the strategies of working in each type of BIM application and the reference to the main benefits and limitations. All parts of the course, including practice, construction, structures and HBIM, were essentially illustrated with study cases selected in accordance with the audience. As so, the proposed program covers diverse sec-

tors of the construction industry, namely, conflict analysis in projects, construction planning, materials take-off, project of structures with the focus on the interoperability capacity of the available software and the activity related with HBIM domain.

Conflicts of Interest

The authors declare no conflicts of interest regarding the publication of this paper.

References

- [1] Sacks, R., Eastman, C., Lee, G. and Teicholz, P. (2018) BIM Handbook: A Guide to Building Information Modeling for Owners, Designers, Engineers, Contractors, and Facility Managers, 3rd Edition. John Wiley and Sons, Inc., Hoboken.
<https://doi.org/10.1002/9781119287568>
- [2] Volk, R., Stengel, J. and Schultmann, F. (2014) Building Information Modeling (BIM) for Existing Buildings—Literature Review and Future Needs. *Automation in Construction*, **38**, 109-127. <https://doi.org/10.1016/j.autcon.2013.10.023>
- [3] Lu, W., Fung, A., Peng, Y., Liang, C. and Rowlinson, S. (2014), Cost-Benefit Analysis of Building Information Modeling Implementation in Building Projects through Demystification of Time-Effort Distribution Curves. *Building and Environment*, **82**, 317-327. <https://doi.org/10.1016/j.buildenv.2014.08.030>
- [4] Sampaio, A.Z. (2021) Maturity of BIM Implementation in the Construction Industry: Governmental Policies. *International Journal of Engineering Trends and Technology*, **69**, 92-100. <https://doi.org/10.14445/22315381/IJETT-V69I7P214>
- [5] Sampaio, A.Z. (2021) BIM Education Required in Construction In: Rodrigues, H., Gaspar, F., Fernandes, P. and Mateus, A., Eds., *Sustainability and Automation in Smart Constructions*, Springer, Cham, 3-9.
https://doi.org/10.1007/978-3-030-35533-3_1
- [6] Lozano-Díez, R.V., López-Zaldívar, O., Herrero del Cura, S. and Mayor, P.L. (2018) Primeras Experiences in the Rule of the BIM Environment: The Case of the Degree in Building of the Polytechnic University of Madrid. *Advances in Building Education: Educative Innovation in Buildings*, **2**, 109-121.
<https://doi.org/10.20868/abe.2018.1.3697>
- [7] Anastasiou, L., Kostaras, N., Kyritsis, E. and Kostaras, A. (2015) The Construction of Scientific Knowledge at an Early Age: Two Crucial Factors. *Creative Education*, **6**, 262-272. <https://doi.org/10.4236/ce.2015.62025>
- [8] BIM Academy (2022) BIM Virtual Project Training.
<https://www.bimacademy.global/work/virtual-project-training/>
- [9] Liu, R. and Hatipkarasulu, Y (2014) Introducing Building Information Modelling Course into a Newly Developed Construction Program with Various Student Backgrounds. *121st ASEE Annual Conference and Exposition*, Indianapolis, 15-18 June 2014, Paper ID: 9291.
- [10] Zamora-Polo, F., Sánchez-Cortés, M.M., Reyes-Rodríguez, A.M. and Sanz-Calcedo, J.C. (2019) Developing Project Managers' Transversal Competences Using Building Information Modelling. *Applied Sciences*, **9**, Article No. 4006.
<https://doi.org/10.3390/app9194006>
- [11] BSI Group (2022) BIM Implementation Training Course.

- <https://www.bsigroup.com/en-ID/building-information-modeling-bim/training-courses-for-building-information-modelling-bim/bim-implementation-training-course/>
- [12] Picó, E.C. (2009) Introduction to BIM Technology. Polytechnic University of Catalonia, Barcelona.
- [13] Donato, V. (2011) Quality of Digital Models in Project Management. Study Days—Design Transformations. Polytechnic University of Turin, Turin.
- [14] Taylor, J., Liu, J. and Hein, M. (2014) Integration of Building Information Modeling (BIM) into an ACCE Accredited Construction Management Curriculum. Associated Schools of Construction. *44th Annual ASC International Conference Proceedings*, 117-124.
<http://ascpro0.ascweb.org/archives/cd/2008/paper/CEUE246002008.pdf>
- [15] Huang, Y. (2018) Developing a Modular Advanced BIM Course in Construction Management. *Journal of Building Construction and Planning Research*, **6**, 198-214.
<https://doi.org/10.4236/jbcpr.2018.64014>
- [16] Araújo, L. (2016) Development of a Wall Library in BIM Methodology. Master's Thesis in Construction, University of Lisbon, Lisbon.
- [17] Sampaio A.Z. and Antunes, B.G. (2020) Quantity Take-Off Process Supported by Building Information Modeling (BIM) Methodology. In: Rodrigues, H., Gaspar, F., Fernandes, P. and Mateus, A., Eds., *Sustainability and Automation in Smart Constructions*, Springer, Cham, 21-28. https://doi.org/10.1007/978-3-030-35533-3_4
- [18] Mota, C. and Sampaio, A.Z. (2016) BIM Model of Structures Used in Construction planning. *National Meeting of Structural Concrete*, Coimbra, 2-4 November 2016, 10. <http://be2016.dec.uc.pt/>
- [19] Oliveira, J.D. and Sampaio, A.Z. (2019) BIM in Structures: Analysis of Interoperability. *ICSAAM 2019: 9th International Conference on Structural Analysis of Advanced Materials*, Ischia, 12-14 September 2019.
<https://aip.scitation.org/toc/apc/2196/1>
- [20] Sampaio, A.Z., Gomes, Augusto, M. and Farinha, T. (2021) BIM Methodology Applied in Structural Design: Analysis of Interoperability in ArchiCAD/ETABS Process. *Journal of Software Engineering and Applications*, **14**, 189-206.
<https://doi.org/10.4236/jsea.2021.146012>
- [21] Sampaio, A. Z., Gomes, A.M. Lite, A.S., Zulueta, P. and González-Gaya, C. (2021) Analysis of BIM Methodology Applied to Practical Cases in the Preservation of Heritage Buildings. *Sustainability*, **13**, Article No. 3129.
<https://doi.org/10.3390/su13063129>
- [22] Sampaio, A. Z., Pinto, A.M., Gomes, A.M. and Lite, A.S. (2021) Generation of a HBIM library Regarding a Palace of the 19th Century in Lisbon. *Applied Sciences*, **11**, Article No. 7020. <https://doi.org/10.3390/app11157020>